

## VFM-F50\_DL Assembly

### **First Batch Note 1**

Use the angled part that comes with the F50\_DL.

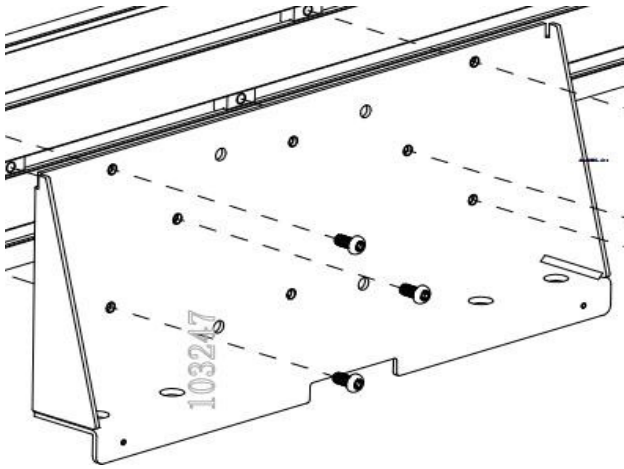

### **First Batch Note 2**

These holes were incorrectly threaded. Drill them out with a 6.5 mm bit before you start.

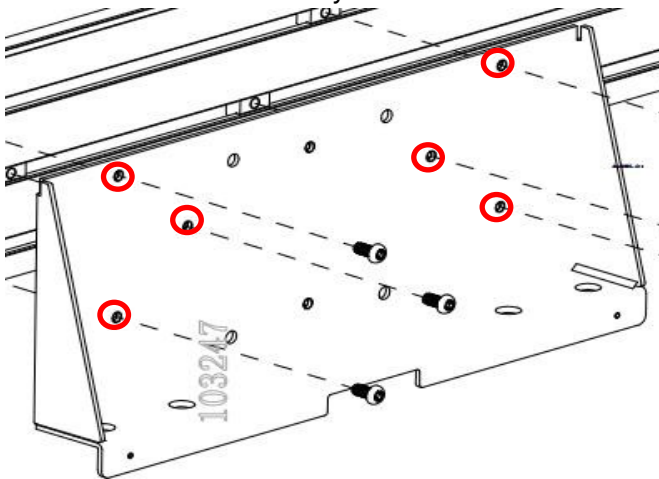

1. Assemble as shown using **6 x M6x12** screws, then attach this assembly to top of F50 floor stand.

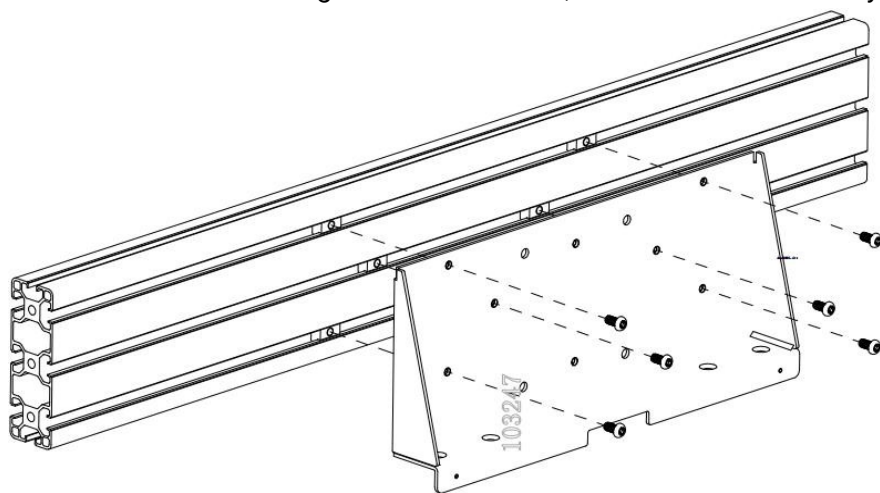

2. Join rails. Note for smaller displays you may only need two of the three sections.

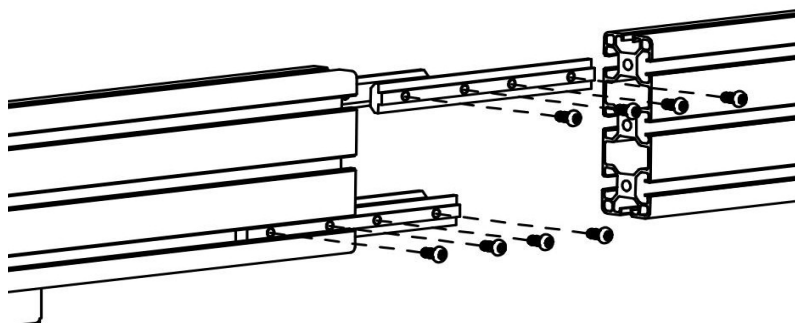

1. Fix wall mount as shown using **6 x M6x12** screws

