

SB-800P SOUNDBAR LOUDSPEAKER OWNERS MANUAL



www.visionaudiovisual.com/techaudio/sb-800p

DECLARATION OF CONFORMITY

Where applicable Vision products are certified and comply with all known local regulations to a 'CB Certification' standard. Vision commits to ensure all products are fully compliant with all applicable certification standards for sale in the EU and other participating countries.

The product described in this owner manual is in compliance with RoHS (EU directive 2002/95/EC), and WEEE (EU directive 2002/96/EC) standards. This product should be returned to the place of purchase at the end of its useful life for recycling.

WARNINGS



CAUTION
RISK OF ELECTRIC SHOCK
DO NOT OPEN



CAUTION: TO REDUCE THE RISK OF ELECTRIC SHOCK DO NOT REMOVE COVER (OR BACK). NO USER-SERVICEABLE PARTS INSIDE. REFER SERVICING TO QUALIFIED SERVICE PERSONNEL.



The lightning flash with arrowhead symbol, within an equilateral triangle, is intended to alert the user to the presence of uninsulated "dangerous voltage" within the product's enclosure that may be of sufficient magnitude to constitute a risk of electric shock to persons.



The exclamation point within an equilateral triangle, is intended to alert the user to the presence of important operating and maintenance (servicing) instructions in the literature accompanying the appliance.

WARNING: TO REDUCE THE RISK OF FIRE OR ELECTRIC SHOCK, DO NOT EXPOSE THIS APPLIANCE TO RAIN OR MOISTURE.

All products are designed and imported into the EU by 'Vision' who is wholly owned by 'Azlan Logistics Ltd.', Registered in England Nr. 04625566 at Lion House, 4 Pioneer Business Park, Clifton Moor, York, YO30 4GH. WEEE Registration: GD0046SY



DECLARATION OF ORIGIN

All Vision products are made in the People's Republic of China (PRC).

USE ONLY DOMESTIC AC OUTLETS

Connecting the unit to an outlet supplying a higher voltage may create a fire hazard.

HANDLE THE POWER CORD WITH CARE

Do not disconnect the plug from the AC outlet by pulling the cord; always pull the plug itself. Pulling the cord may damage it. If you do not intend to use your unit for any considerable length of time, unplug the unit. Do not place furniture or other heavy objects on the cord, and try to avoid dropping heavy objects on it. Do not tie a knot in the power cord. Not only could the cord be damaged, but a short circuit could also be caused with a consequent fire hazard.

PLACE OF INSTALLATION

Avoid installing this product under the following conditions:

- Moist or humid places
- Places exposed to direct sunlight or close to heating equipment
- Extremely cold locations
- Places subject to excessive vibration or dust
- Poorly ventilated places

Do not expose this product to dripping or splashing. **DO NOT PLACE OBJECTS FILLED WITH LIQUIDS ON OR NEAR THIS PRODUCT!**

MOVING THE UNIT

Before moving the unit, be sure to pull out the power cord from the AC outlet and disconnect the interconnection cords with other units.

WARNING SIGNS

If you detect an abnormal smell or smoke, turn this product off immediately and unplug the power cord. Contact your reseller or Vision.

PACKAGING

Save all packing material. It is essential for shipping in the event the unit ever needs repair.

IF ORIGINAL PACKAGING IS NOT USED TO RETURN THE UNIT TO THE SERVICE CENTRE, DAMAGE IN TRANSIT WILL NOT BE COVERED BY WARRANTY.

WATTS

The most consistent standards for measuring watts are "Program Power" and "RMS" because these measure average sustained levels.

Where loudspeakers have integrated amplifiers, then load (resistance, measured in ohms) is known so the wattage rating is fixed.

REAR PANEL

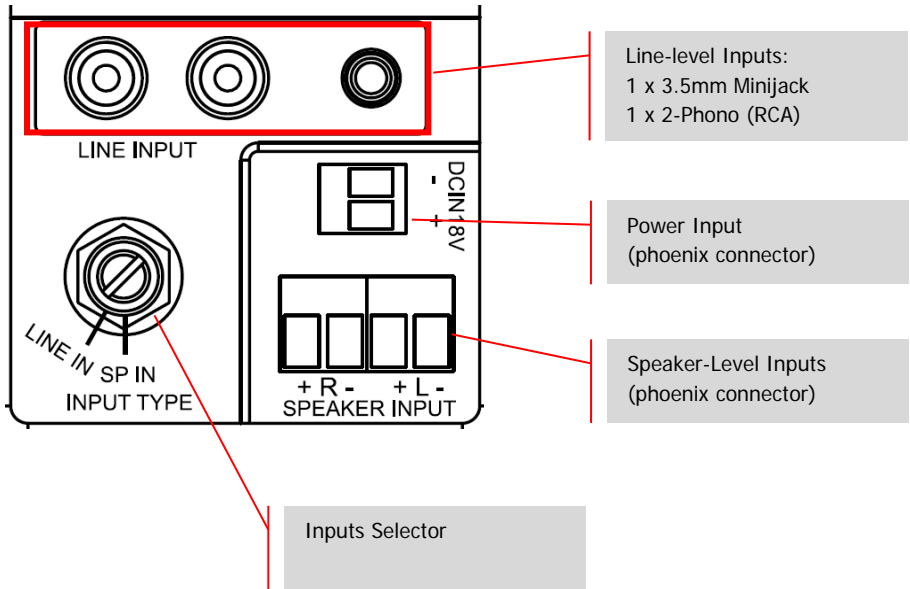

UNDERSIDE

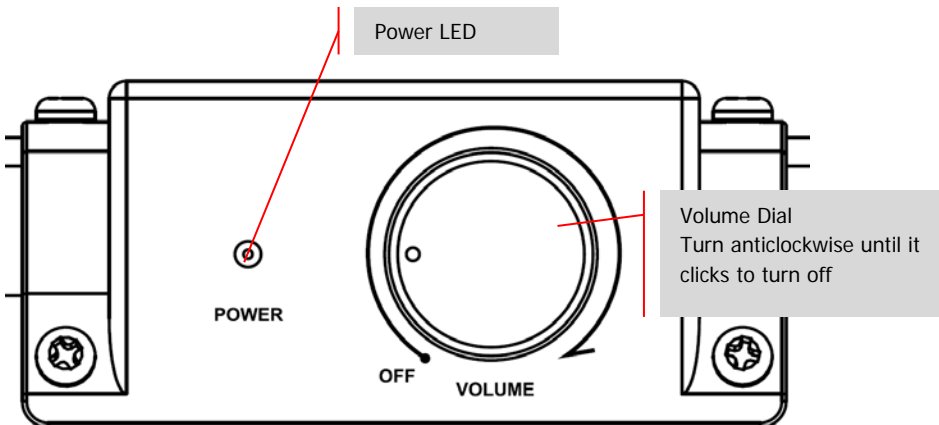

INSTALLING ON WALL

1. FIT BRACKETS TO WALL

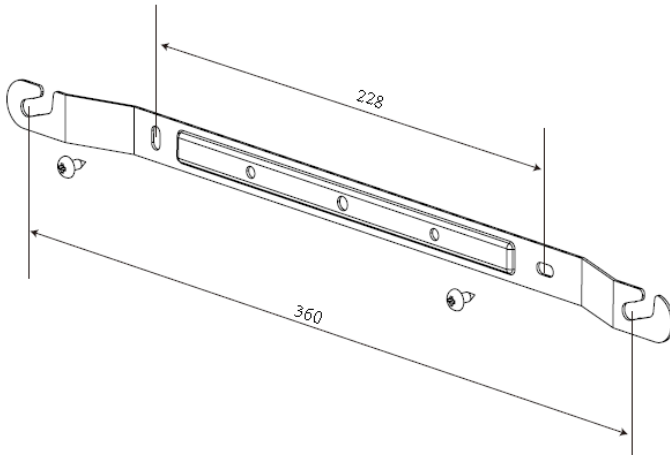

2. HOOK SOUNDBAR ONTO BRACKET

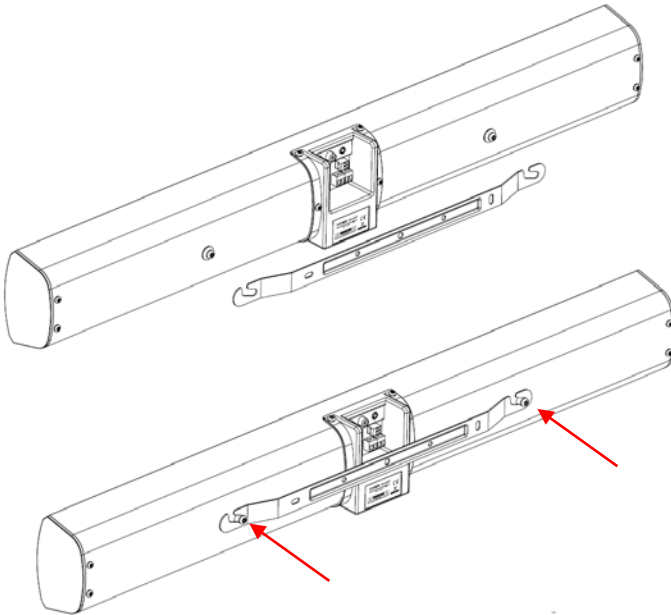

INSTALLING UNDER SCREEN

1. LAY DISPLAY ON VIEWING SURFACE

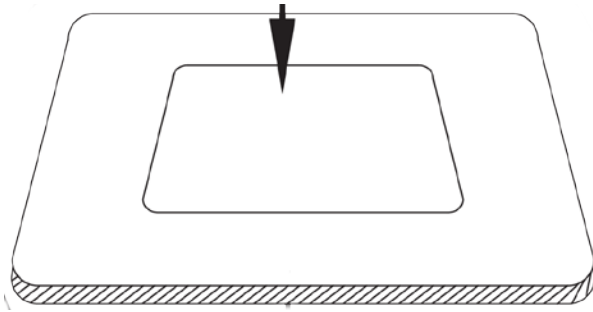

2. PUT SOUNDBAR UNDER DISPLAY

3. FIX MOUNTING STRIPS TO SOUNDBAR

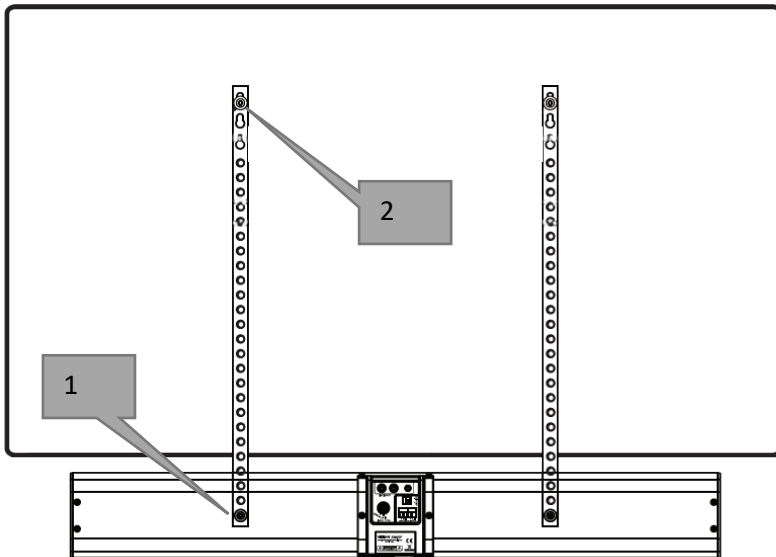

4. POSITION STRIPS OVER DISPLAY MOUNTING HOLES

5. POSITION WALL MOUNT EARS ON DISPLAY

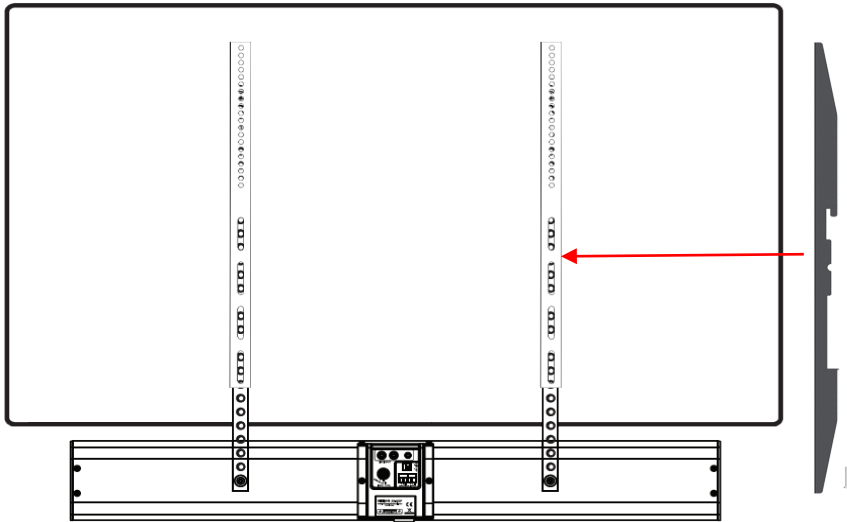

6. FIX WALL MOUNT EARS TO DISPLAY

7. HANG DISPLAY IN PLACE

INPUT TYPE SELECTOR

LINE LEVEL

SB-800P has an amplifier built in. It can accept stereo line-level signal which comes out of the headphone jack on a laptop or phone.

To adjust volume turn the dial on the bottom (note this product does not have a remote control).

SPEAKER LEVEL

If flat-panel display has an amplifier built in, select SP IN to receive the more powerful speaker-level signal. This will bypass the amplifier in the SB-800P. Generally this will use unshielded speaker cable which is often black and red.

To adjust volume use display remote control. There is no need to run power to soundbar.

NOTE: Do not connect SPEAKER-LEVEL signal to the LINE-LEVEL inputs.

SPECIFICATIONS

PRODUCT DIMENSIONS: 756 x 75 x 99mm / 29.8" x 2.9" x 3.9" (width x depth x height)

PACKAGED DIMENSIONS: 870 x 92 x 135 mm / 34" x 3.6 " x 5.3"

PRODUCT WEIGHT: 2 kg / 4.4 lb

PACKAGED WEIGHT: 2.7 kg /5.9 lb

CONSTRUCTION MATERIAL: ABS Plastic

COLOUR: White

TECHNICAL DETAILS:

Amplifier Output: 2 x 15w watts (RMS)

Woofer: 2 x 3.5"

Tweeter: 2 x 0.5"

Input 1: Minijack (3.5mm)

Input 2: 2-Phono (RCA) (inputs are summed)

Speaker Input (from flat panel if it has internal amplifier): Removable Phoenix type

Output Impedance: 8 ohms

Sensitivity: 88dB (1w/1m)

Frequency response: 120Hz-20kHz

ACCESSORIES INCLUDED:

2 x Wall brackets

2 x 700mm mounting strips – to hang soundbar beneath flat panel.

Note: no input cables are included

POWER SUPPLY: 100-240v 50/60Hz AC External Power Supply – 18 volt / 1 amp

Transformer integrated into plug. Includes interchangeable plugs: UK/EU/US/AU. DC tail length: 4m. Transformer dimensions: 75 x 38 x 50mm / 3" x 1.5" x 2" (tall x wide x deep) including prongs

WARRANTY: Lifetime return-to-base

2 years onsite (UK only)

COMPLIANCE: RoHS, WEEE, CE/EMC, FCC, RCM-POC, RCM-SDOC

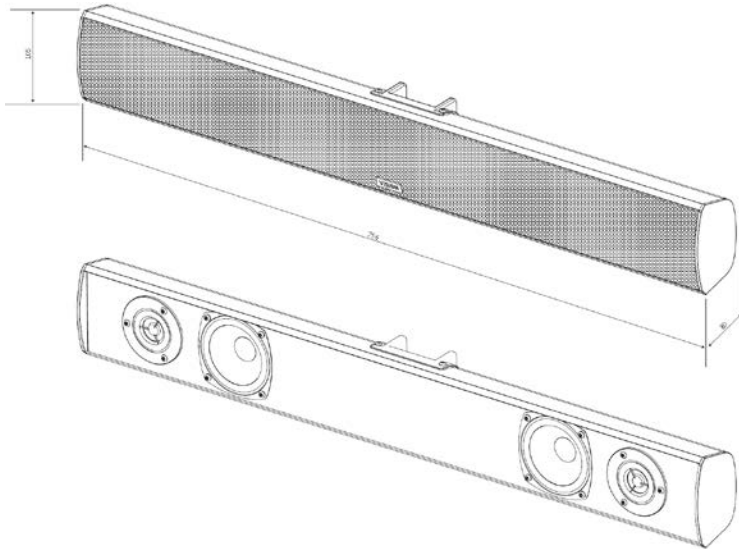
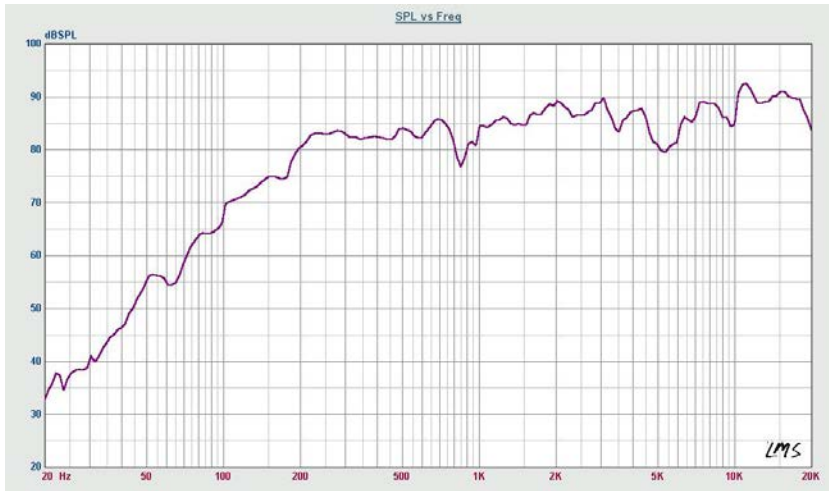

LIFETIME RETURN-TO-BASE WARRANTY

This product comes with a lifetime return to base warranty. If you have a problem you are required to provide a DETAILED DESCRIPTION of the fault.

Some Vision products are very technical and require troubleshooting all elements of the installation as it may not be the Vision product at fault. Because of this the manufacturer may refuse to replace the item if an adequate description is not provided.

- This warranty applies only to the original purchaser and is not transferable.
- This warranty protects you against the following:
 - Failure of any components, including the power supply.
 - Damage when the product is first removed from its packaging if reported within 24 hours of purchase.
- If the product is DOA (dead on arrival), you have 21 days from purchase date to notify the national distributor via your AV reseller.
- The original purchaser is responsible for shipment of the product to the Vision's appointed service centre.
- The liability of Vision is limited to the cost of replacement of the faulty unit under warranty except for death or injury (EU85/374/EEC).
- If the product is end of line (EOL) the Vision will provide a credit instead of replacement.
- This warranty does not protect this product against faults caused by abuse, misuse, incorrect installation, unstable or faulty power input, or modification.

Vision aims to send a replacement item within 5 working days however this may not always be possible, in which case it will be sent as soon as practicably possible. UK End users and resellers can request support at <http://www.visionaudiovisual.com/support>

LEGAL DISCLAIMER: Because we are committed to improving our products, the details above may change without prior warning. This User Manual is published without warranty and any improvements or changes to the User Manual necessitated by typographical errors, inaccuracies of current information, or improvements to programs and/or equipment, may be made at any time and without notice. Such changes will be incorporated into new editions of the User Manual.